

POLYETHYLENE BUOY

GBM-2500



Management System approved by LRQA to standards ISO 9001:2015



Diameter: 2.5 m Volume: 5.25 m³
For semi-exposed sites

With its modular design, the hybrid buoy type GBM-2500 can match various applications. The combination of its 3 main elements is custom-made according to site conditions and client requirements.

Features:

- 4 segments of float in virgin polyethylene, UV stabilised and precompounded to reduce colour ageing, with standard wall thickness 10 mm and expanded polystyrene (EPS) foaming
- Polyethylene or aluminium spar
- Central structure in galvanised steel

Advantages:

- **High visibility** spar compared to lattice towers
- Buoy with ballasted tail for **improved stability**
- Buoyancy ensured by **modular design**, even in the case of collision

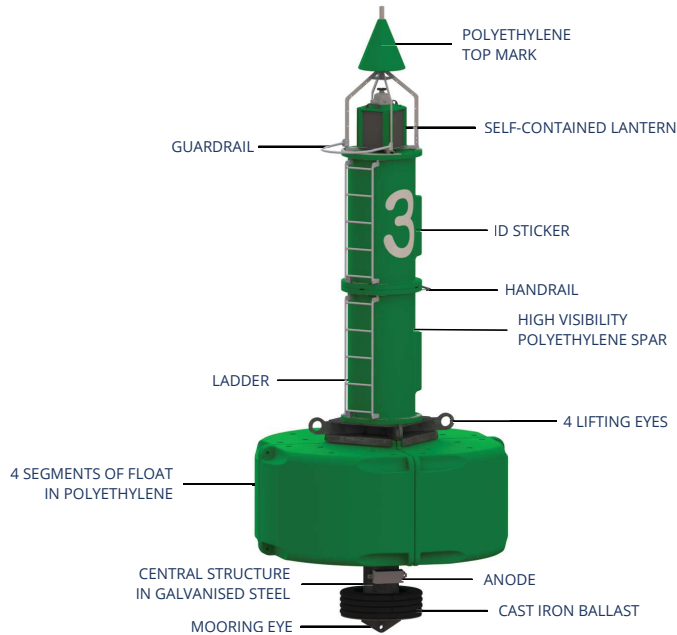

GBM-2500-TT-HVL

Configuration examples:

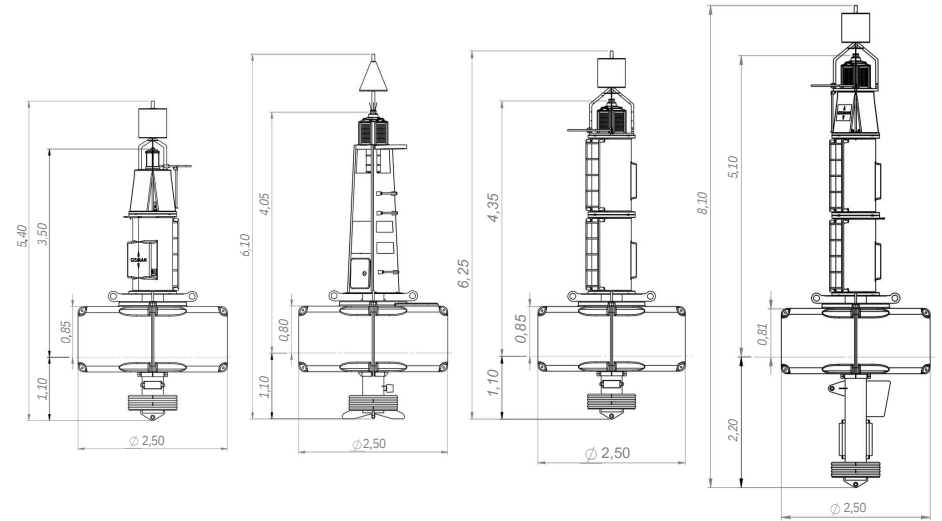

GBM-2500-TT-HVM

GBM-2500-SAT-HVA-2.5

GBM-2500-TT-HVL

GBM-2500-LTT-HVXL

	GBM-2500-TT-HVM	GBM-2500-SAT-HVA-2.5	GBM-2500-TT-HVL	GBM-2500-LTT-HVXL
Diameter (m)	2.5	2.5	2.5	2.5
Volume (m³)	5.25	5.25	5.25	5.25
Total weight (kg)	1260	1350	1280	1530
Reserve buoyancy (m³)	4.0	3.9	4.0	3.8
Draught (m)	1.1	1.1	1.1	2.2
Freeboard (m)	0.85	0.8	0.85	0.8
Focal plane (m)	3.5 (with GSC-5-SS)	4.05 (with GSC-8)	4.35 (with GSC-8)	5.1 (with GSC-8)
Overall height (m)	5.4	6.1	6.25	8.1

Other configurations are available, please contact us at contact@gisman.fr

Options available on request:

- Echomax radar reflector
- ID plates, stickers & retro-reflective tape
- Ladder, handrail
- Lockable door on high visibility spar

